

PRODUCT SPECIFICATION SHEET

Product Code: **DTC06000L**



DIESELCADET 6000L - FREE STANDING TANK (1586 Gal.)

6000L free standing DieselCadet cartage tank, manufactured from specifically formulated diesel grade polyethylene. Complete with pad-lockable filler cap, strainer, drain plug, breather system, 2" suction tube, earth strap to prevent static build up when filling tank, and SureFit pin mounting point for secure mounting.

- » Manufactured from specifically formulated diesel grade polyethylene that meets International Regulation ECE R34.01 requirements
- » Diesel grade polyethylene construction, complies with AS1940-2004 and AS2809.2-2008
- » Innovative splash resistant breather system specifically designed for diesel transport
- » Earth strap to prevent static build up when filling tank
- » Drain plug for easy cleaning
- » Pad-lockable filler cap with strainer
- » No-spill fill system prevents wastage
- » Removable plate allows access to tank
- » 2" suction tube access
- » SureFit pin mounting points for secure mounting
- » 2760 (L) x 2000 (W) x 1540 (H)

- SPECIFICATIONS -

Capacity (brim full) Litres:	6000	Tank Material:	Polyethylene
Capacity (brim full) U.S. Gallons:	1585	Tank Lid diameter (mm/in):	455 / 17.9
Tank Length (mm/in):	2760 / 108.7	Pump Rating (L/min):	
Tank Width (mm/in):	2000 / 78.7	Pump Pressure (psi):	
Tank Height (mm/in):	1540 / 60.6	Tank Warranty (years):	15
Tank Weight (Kgs):	300	Engine Warranty (years):	

NOTE: All pricing displayed on this website is inclusive of GST. Freight subject to normal freight agreement.

T: 1800 816 277
F: (03) 5866 3019

W: www.tti.com.au
E: sales@tti.com.au



Australia's Safest Tanks and Trailers



 MASS: 801962.81 Kg

 ALL DIMENSIONS ARE IN mm

BENDING: K-FACTOR:

 MACHINING:

 TAPPING:

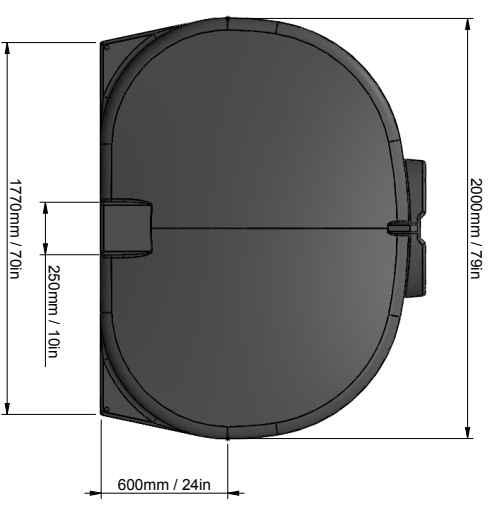
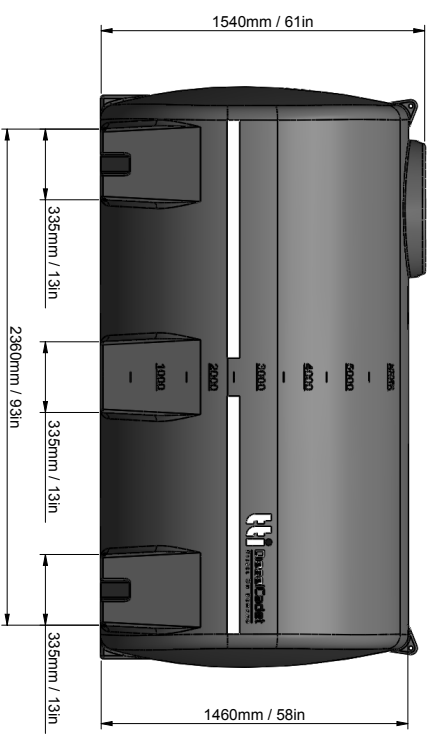

MATERIAL: LLDPE

 MATERIAL SIZE:

NOTES:

 1. WORK TO DIMENSIONS, DO NOT SCALE.

 2. REMOVE ALL VISIBLE BURRS.

GENERAL TOLERANCES UNLESS NOTED

 . . . 0 ±0.5

 . . . 0.0 ±0.25

 . . . 0.00 ±0.1

 . . . ANGLE ±1/2°

 . . . FINISH 32µm

REV	DESCRIPTION	DRN	CHK/APP	DATE	SCALE	NONE	DWG NO	PERMISSION
					SHT SIZE	A3	DTC06000L	1 OF 1
					DATE	12/04/2016	DESCRIPTION	6,000L DIESEL TANK
					DRN	JB	FILE NAME	TANK DRAWING
					CHK	RB		
					APP	RB		

TTI TransTank®

 INTERNATIONAL

 Australia's Safest Tanks and Trailers

In part or in full with out the written permission of TTI.

