

INDIVIDUALLY ENCLOSED HOSE REEL
FOR LOW, MEDIUM AND HIGH PRESSURE FLUIDS
AIR, HOT AND COLD WATER, LUBRICANTS, ANTIFREEZE, WINDSHIELD WASH, GREASE AND AdBlue

MADE IN SPAIN



NEW DESIGN
IMPROVED PERFORMANCE
INCREASED HOSE CAPACITY

NEW DESIGN: PROVIDES EASIER INSTALLATION AND SERVICE IN ANY MOUNTING POSITION.

IMPROVED PERFORMANCE: FULL PORT REDUCES PRESSURE LOSS TO A MINIMUM. BALL BEARINGS REQUIRE LESS POWER TO PULL OUT THE HOSE AND EXTEND POWER SPRING LIFE.

INCREASED HOSE CAPACITY: UP TO 15 M (50') X 1/2" HOSE.

SAMOA INTRODUCES THE 507 HOSE REEL.

INNOVATIVE SOLUTIONS FOR AN OPTIMUM QUALITY AND OUTSTANDING PERFORMANCE.

ENCLOSED REELS PROBLEMS SOLVED

Using modern materials and a unique design, the 507 hose reel eliminates all typical disadvantages of enclosed reels such as limited hose capacity, excessive weight, difficult maintenance, etc.

LONG LIFE QUALITY POWER SPRING

The power spring is manufactured with high quality fatigue resistance steel, guaranteed for long and trouble free operation. Depending on the hose length and weight, each reel uses one of three optimized performance springs to adjust the spring characteristics to each application needs.

SUPERIOR STRUCTURAL STABILITY AND LIGHT WEIGHT

Shields are manufactured in aluminum and are designed for superb structural stability. Composite spool and side panels contribute, together with the aluminum shields, to make a light weight assembly for an easier installation.



INCREASED HOSE CAPACITY

The 507 hose reel exclusive design allows to efficiently handle up to 15 m (50') of 1/2" hose.

Models for 18 m (60') are also available for installations allowing a minimum of 3 m (10') of hose hanging from the reel.

EIGHT POSITION LATCHING MECHANISM

The hose reel can be latched once the desired hose length is pulled out from the spool. Eight latching teeth distributed in two opposite racks provide multiple hose lock positions.

PRESSURE BALANCED SWIVEL

Samoa low, medium and high pressure balanced swivels are designed to minimize hose retraction resistance, even at high working pressure. Their simple design provides unrestricted flow, easy access for service and a long life trouble free operation.



FLUID COMPATIBILITY

Nickel protected shaft and swivel provide maximum fluid compatibility. The 507 series reels can be used with a wide variety of fluids: low pressure air, water and windshield washer, medium pressure lubricants and antifreeze solution, high pressure grease and cold and hot water. The shaft is manufactured in one single piece, with no threaded unions, eliminating the risk of leaks.

SUPERB CORROSION RESISTANCE

Sintered powder coated aluminum shields, composite material spool and side panels and stainless steel fasteners provide superior corrosion resistance. The hose reel power spring is accessible for service and is protected by a lid from moisture and dust.

FULL PORT SHAFT AND SWIVEL

Full port shaft and swivel provides maximum fluid delivery since flow restrictions are minimized.

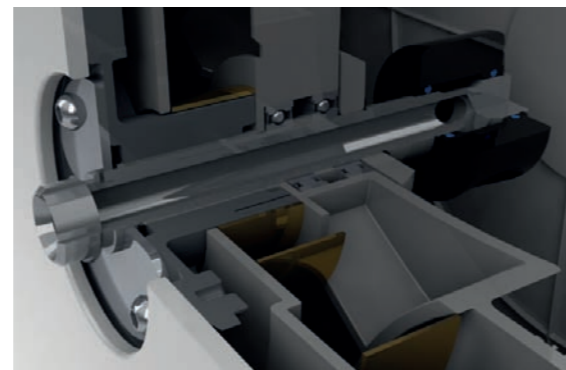

EASY MAINTENANCE AND SERVICE

Removing one of the side panels provides full access for swivel inspection, hose replacement or power spring load adjustment. Removing the other side panel provides full access to the ratchet mechanism. Any maintenance activity can be done without dismounting the reel from its position.

SPOOL MOUNTED ON BALL BEARINGS

The spool is mounted on two permanently lubricated ball bearings providing a smooth and comfortable hose extraction. Bearings provide optimal hose retraction even in the most demanding situations, such as high ceiling mounted reels with heavy fluid hoses and dispensing gins. Ball bearings also help to increase reel life and to eliminate wobbling.

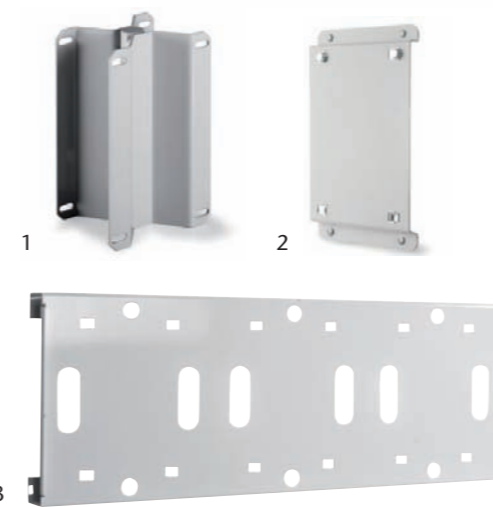

1. Pivoting wall mount bracket (360 111).
2. Fast mount bracket (360 119).
3. Reel mounting channel for two (360114), three (360115) and five (360117) reels.

EASY INSTALLATION

Thanks to its light weight and the reversible base design with four holes combined with slots, the 507 series hose reels are very easy to install, even for one installer working alone. For making its installation even easier, a fast mounting bracket (P.N. 360 119) or a pivoting bracket (P.N. 360 111) are available. 507 series hose reels can use any of the SAMOA hose reel mounting accessories.

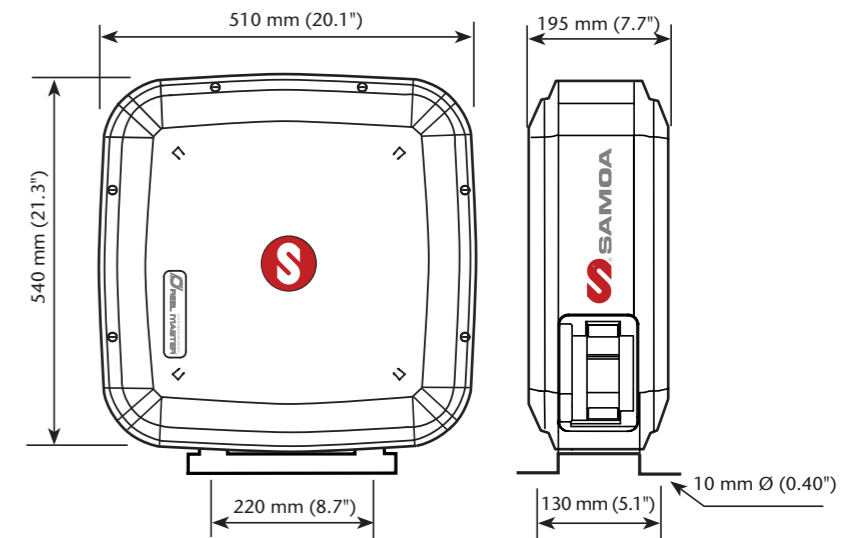

VERSATILE INSTALLATION

Hose reel brackets can be mounted in three positions in order to select the one that offers smooth tangential hose extraction. Reels are shipped with their brackets in the RF position and can be easily changed on site.

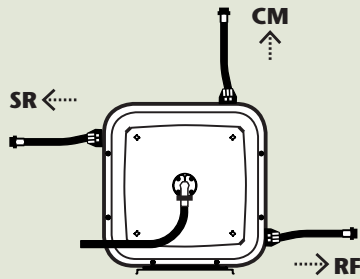

SR: SIDE ROLLER

Use this position when the hose is pulled parallel to the mounting surface. Typical use is when the reel is mounted to a wall. However this position might create an obstacle in the shop as the hose is hanging further out from the wall. The use of a pivoting bracket (360 111) is recommended with this position to reduce the torque on the reel brackets when submitted to lateral pull, see previous page.

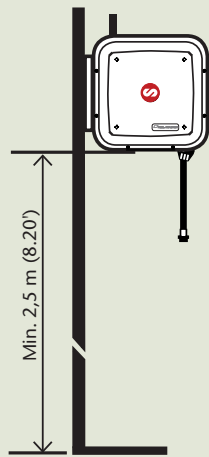

CM: CEILING MOUNT

Use this position when the hose is pulled perpendicularly to the mounting surface. Typical use of this position is when the reel is mounted to a ceiling or a hose reel stand. This position can also be used when the reel is mounted inside lubrication pits.

RF: REAR FLOOR

Use this position when the hose is pulled out tangentially to the mounting surface. Typical use of this position is when the reel is mounted to a wall or on a tank. When mounted to a wall, it has the advantage that the hose lays close to the wall and does not represent an obstacle. Additionally, the torque on the bracket created when the hose is pulled laterally is minimized.

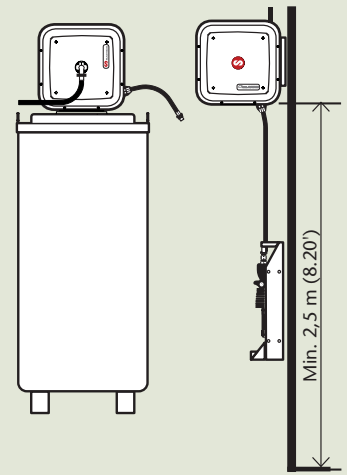

PART N°	HOSE LENGTH	HOSE DIAMETER NONINAL - I.D. X O.D.	OUTLET THREAD	INLET THREAD	HOSE PRESSURE RATING	HOSE BURST PRESSURE	NET WEIGHT
COMPRESSED AIR AND LOW PRESSURE WATER							
507 101	10 m - 30'	3/8" - 17 x 10 mm	R 3/8" (M) ⁽¹⁾	R 1/2" (M) ⁽¹⁾	20 bar - 300 psi	45 bar - 650 psi	18,4 kg (40.6 lb)
507 121	15 m - 50'	3/8" - 17 x 10 mm	R 3/8" (M) ⁽¹⁾	R 1/2" (M) ⁽¹⁾	20 bar - 300 psi	45 bar - 650 psi	20,7 kg (45.6 lb)
507 122	15 m - 50'	1/2" - 20 x 12,5 mm	R 1/2" (M) ⁽¹⁾	R 1/2" (M) ⁽¹⁾	20 bar - 300 psi	45 bar - 650 psi	21,4 kg (47.2 lb)
HOT AND COLD WATER 150 ° C - 300° F MAXIMUM TEMPERATURE							
507 421	15 m - 50'	3/8" - 16 x 10 mm	G 3/8" (H/M) ⁽²⁾	G 3/8" (H/M) ⁽²⁾	170 bar - 2,500 psi	680 bar - 10,000 psi	22,2 kg (48.9 lb)
OIL, ANTIFREEZE, AIR AND WATER							
507 202	10 m - 30'	1/2" - 18 x 12,5 mm	G 1/2" (H/M) ⁽²⁾	G 1/2" (H/M) ⁽²⁾	100 bar - 1,500 psi	400 bar - 6,000 psi	18,9 kg (41.7 lb)
507 222	15 m - 50'	1/2" - 18 x 12,5 mm	G 1/2" (H/M) ⁽²⁾	G 1/2" (H/M) ⁽²⁾	100 bar - 1,500 psi	400 bar - 6,000 psi	21,4 kg (47.2 lb)
507 212	18 m - 60'	1/2" - 18 x 12,5 mm	G 1/2" (H/M) ⁽²⁾	G 1/2" (H/M) ⁽²⁾	100 bar - 1,500 psi	400 bar - 6,000 psi	22,2 kg (48.9 lb)
WASTE OIL SUCTION							
507 503	6 m - 20'	5/8" - 23 x 16 mm	G 1/2" (H/M) ⁽²⁾	G 1/2" (H/M) ⁽²⁾	100 bar - 1,500 psi	400 bar - 6,000 psi	19,1 kg (42.1 lb)
WINDSHIELD WASHER AND DEGREASERS							
507 602	10 m - 30'	1/2" - 21 x 12,5 mm	G 1/2" (H/M) ⁽²⁾	G 1/2" (H/M) ⁽²⁾	20 bar - 300 psi	80 bar - 1,200 psi	19 kg (41.9 lb)
507 622	15 m - 50'	1/2" - 21 x 12,5 mm	G 1/2" (H/M) ⁽²⁾	G 1/2" (H/M) ⁽²⁾	20 bar - 300 psi	80 bar - 1,200 psi	21,5 kg (47.4 lb)
GREASE							
507 300	10 m - 30'	1/4" - 14 x 6,4 mm	R 1/4" (M) ⁽¹⁾	G 1/4" (H/M) ⁽²⁾	350 bar - 5,000 psi	1.400 bar - 20,000 psi	18,8 kg (41.4 lb)
507 301	10 m - 30'	3/8" - 17 x 10 mm	R 1/4" (M) ⁽¹⁾	G 3/8" (H/M) ⁽²⁾	280 bar - 4,000 psi	1.120 bar - 16,000 psi	19,5 kg (43 lb)
507 321	15 m - 50'	3/8" - 17 x 10 mm	R 1/4" (M) ⁽¹⁾	G 3/8" (H/M) ⁽²⁾	280 bar - 4,000 psi	1.120 bar - 16,000 psi	22,6 kg (49.8 lb)
507 311	18 m - 60'	3/8" - 17 x 10 mm	R 1/4" (M) ⁽¹⁾	G 3/8" (H/M) ⁽²⁾	280 bar - 4,000 psi	1.120 bar - 16,000 psi	23,5 kg (51.8 lb)
AdBlue (DEF)							
507 702	10 m - 30'	1/2" - 21 x 12,5 mm	G 1/2" (H/M) ⁽²⁾	G 1/2" (H/M) ⁽²⁾	20 bar - 300 psi	80 bar - 1,200 psi	19 kg (41.9 lb)
507 722	15 m - 50'	1/2" - 21 x 12,5 mm	G 1/2" (H/M) ⁽²⁾	G 1/2" (H/M) ⁽²⁾	20 bar - 300 psi	80 bar - 1,200 psi	21,5 kg (47.4 lb)

(1) Swaged male tapered threads.

(2) Swaged 60° cone nut and 60° double male adaptor.

• Models with 18 m - 60' of hose should be used in installations allowing a minimum of 3 m - 10' of fluid hose hanging from the reel, and never with the hose totally coiled inside the reel.
 • All models with hose include a 0,8 m - 2.5' inlet hose.