

PRODUCT DATA SHEET

BIA SUB550 • 810762



BRAND

**BIANCO
PUMPZ**

PRODUCT DETAILS

The Bianco SUB550 is a light duty, occasional use vortex style pump

The generous internal clearances enable this pump to cope with lightly contaminated water containing soft solids such as leaves or other non-abrasive organic materials

If you have a general de-watering task, the SUB550 is a great choice

BENEFITS

- Light and compact - easy to use
- Great value pump for light duties and occasional use
- Automatic operation controlled by a flexible float

FEATURES

- Quality pump materials and construction to ensure reliable operation
- Multi-fit hose tail

CAUTIONS

- Not intended for continuous operation such as water features
- Not suitable for potable water applications
- Not suitable for use with biological wastewater

TECHNICAL DATA

RATED POWER (W)	550W
MAX. FLOW [LPM]	265 lpm
RATED FLOW [M3/H]	8 m3/h
MAX. HEAD [M]	8m
WORKING TEMPERATURE	< 40°C
LIQUID TEMPERATURE	2°C - 35°C
MAX. IMMERSION DEPTH	3m
MAX. DIA. OF PARTICLE	< 35mm
MOTOR DUTY	Continuous S1
MOTOR PROTECTION LEVEL	Class F
MOTOR PROTECTION	Auto resetting thermal overload
CAPACITOR	10uF
MOTOR SHAFT	304 Grade S/S

RATED VOLTAGE	220V-240V 50 Hz
RATED CURRENT	2.7 A @ 230V
POWER CABLE TYPE	XX
LENGTH OF POWER CABLE	10m
PROTECTION CLASS	IPX8
IMPELLERS	1 of Glass reinforced (25%) Nylon
HYDRAULIC BODY	Glass reinforced (30%) Polypropylene
INLET STRAINER	Open
OUTLET	1 1/2" BSP
SEALS	Lip seal
AUTOMATION FUNCTION	Flexible Float Mechanism
NET WEIGHT (KG)	Pump only 4.9kg
PACKAGE DIMENSION	200 L x 165 W x 385 H (mm)

HYDRAULIC PERFORMANCE

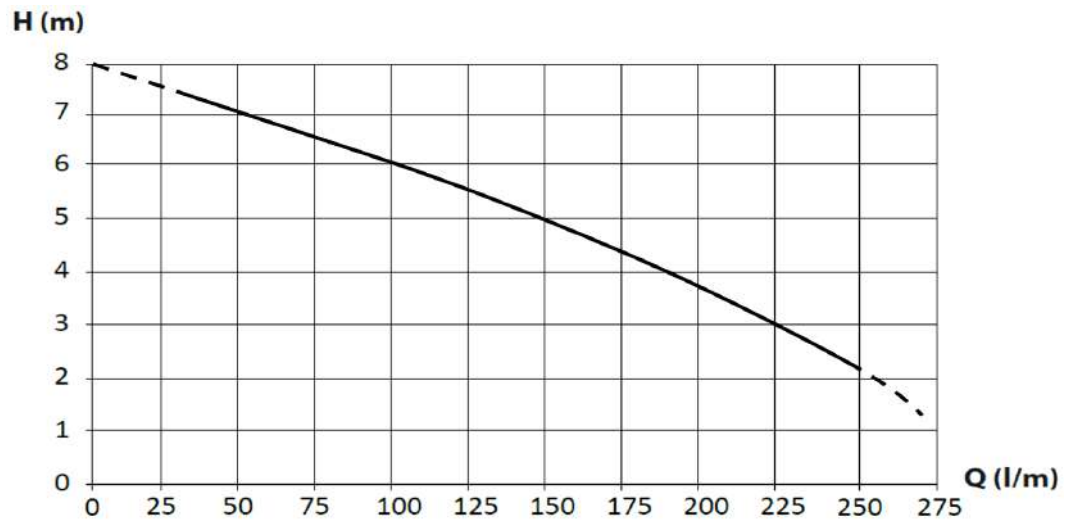

DIMENSIONS

DIMENSIONS

306 mm high

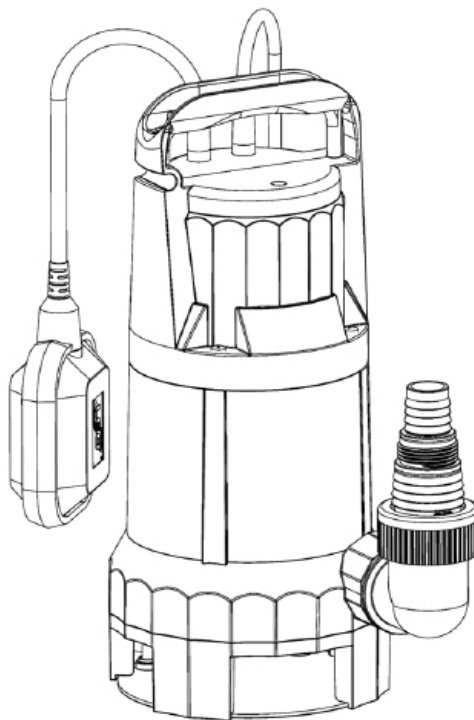

BASE DIAMETER

180 mm

WARRANTY / CERTIFICATIONS

